



BEARING SPECIALISTS ASSOCIATION

We build relationships

BEARING SPECIFIC TOPICS

- Bearing Installation & Fitting
- Bearing Repair
- Hybrid Ceramic Ball Bearings
- Linear Bearings
- Plane Bearings
- Seal Selection
- Spherical Plain Bearings
- Vibration Analysis
- Wear Sleeves and Other Shaft Repair Options
- Planetary Roller Screws
- Bearings for the Food & Beverage Industry
- Split Roller Bearing Technology
- Bearing Mounting Tools

BEARING INDUSTRY INFORMATION

- Bearing Standards Organizations
- Brief History of Bearings
- The Domestic Bearing Industry: Investing in the Future
- History of Adhesives
- Load Ratings & Bearing Life
- Status of Bearing Load Ratings

BEARING BRIEFS

BSA website | Follow us on



Bearing Mounting Tools

Bearings are made to exacting tolerances and have very fine surface finishes. In order to maintain the geometrical precision and the surface integrity of ball and roller bearing raceways and rolling elements, it is mandatory that care in storage and handling and installation be observed. Although the hardened bearing steel used to manufacture bearing components can withstand heavy pressures during operation, bearings are vulnerable to the stresses of metal-to-metal contact that occurs when they are mishandled. When a bearing is bumped or dropped, rolling contact damage usually results. Either the raceways are dented (brinelled) or scuffed. Damaged areas become the focal points for premature failure.

The best way to insure maximum performance and anticipated life from rolling bearings, is taking extreme care during the installation process. Utilizing the proper installation tools is the first step in assuring a successful result.

Preparation is the key to any successful bearing installation. Before a bearing is drawn from its place of storage, an organized work area must be created that insures cleanliness, safety and easy access to all required tools.

The bearing installation tools discussed herein are applicable to a variety of sizes and styles of bearing. However, they may not work in all situations so care must be taken when you make your selection.

Use proper bearing installation tools to avoid misuse of hammers, chisels, screwdrivers, torches and other general tools that will contribute to permanent bearing damage.

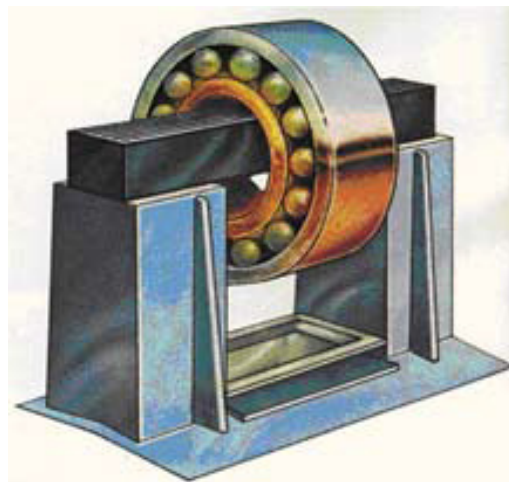

Small and medium size bearings with interference fit inner rings are commonly mounted with the aid of a bearing heater. The purpose of the bearing heater is to expand the inner ring enough so that the bearing can be slipped on the shaft, up to the shoulder without the use of force. Bearing heaters have many advantages but can also destroy a bearing very quickly. Bearing heaters should be equipped with certain safe guards to prevent permanent bearing damage.

The bearing heater should have a timing cycle. This timer turns the heater on and off every few seconds until the bearing reaches its selected temperature. This will prevent brinelling from rapid heating.

Since the bearing becomes magnetized during heating, some heaters feature a demagnetizing cycle. It is strongly recommended using a heater with this feature.

In order to prevent overheating, the bearing heater should be equipped with a temperature probe. If this is not the case, other monitoring procedures must be employed.

NOTE: NEVER HEAT A BEARING TO MORE THAN 120° C (250° F).

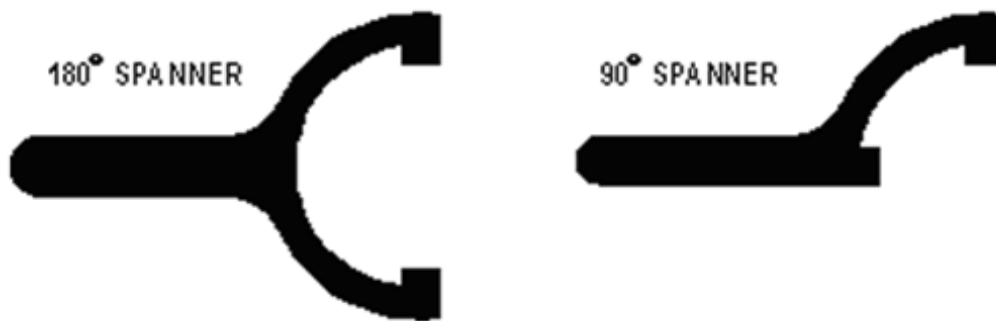

When installing tapered bore bearings that utilize an adapter sleeve and locknut, a spanner wrench is used to complete the assembly and set the clearance. A spanner is a specialized wrench with a series of pins or tabs around the circumference. These pins or tabs fit into the notches of a locknut. The 90° spanner is the most common; however the 180° spanner requires less effort since all of the force applied at the handle is translated to torque on the nut.



When it becomes necessary to remove a bearing from an assembly, care must be taken to avoid damage to raceways and rolling elements. In these instances, utilize a bearing puller. There is wide variety of sizes, capacities and styles from which to choose.



Occasionally it becomes necessary to lightly strike a bearing in order to accomplish installation or removal. In this instance, a “dead blow hammer” is recommended. This type of hammer is manufactured of a hard plastic with the head filled with a “shot” material to deaden the blow and prevent bounce back of the head.

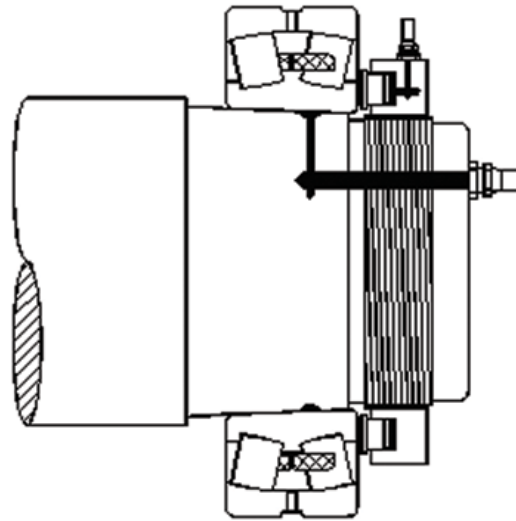

The installation of large diameter bearings often requires the use of hydraulics for mounting and removal. This makes the job easy and fast and eliminates the huge physical effort needed to do the job. Hydraulics are commonly used for tapered bore bearings and occasionally for cylindrical bore bearings.

Hydraulic fluid is pumped through the shaft to a groove under the bearing where the hydraulic pressure expands the inner ring. This eliminates the force required to stretch the inner ring as it is being driven up the taper. The inner ring can be mounted using a standard nut or a hydraulic nut (shown).

Hydraulic nuts are made by a number of manufacturers but all employ the same principle: A nut of standard thread is modified so that there is a hydraulic ram sealed in the inboard face. The ram is actuated by hydraulic fluid introduced through the O.D. of the nut. Pressure against the outboard face of the inner ring drives the bearing up the tapered journal.